

REVISION RECORD				
REV	ECN	DESCRIPTION	DRFT	DATE

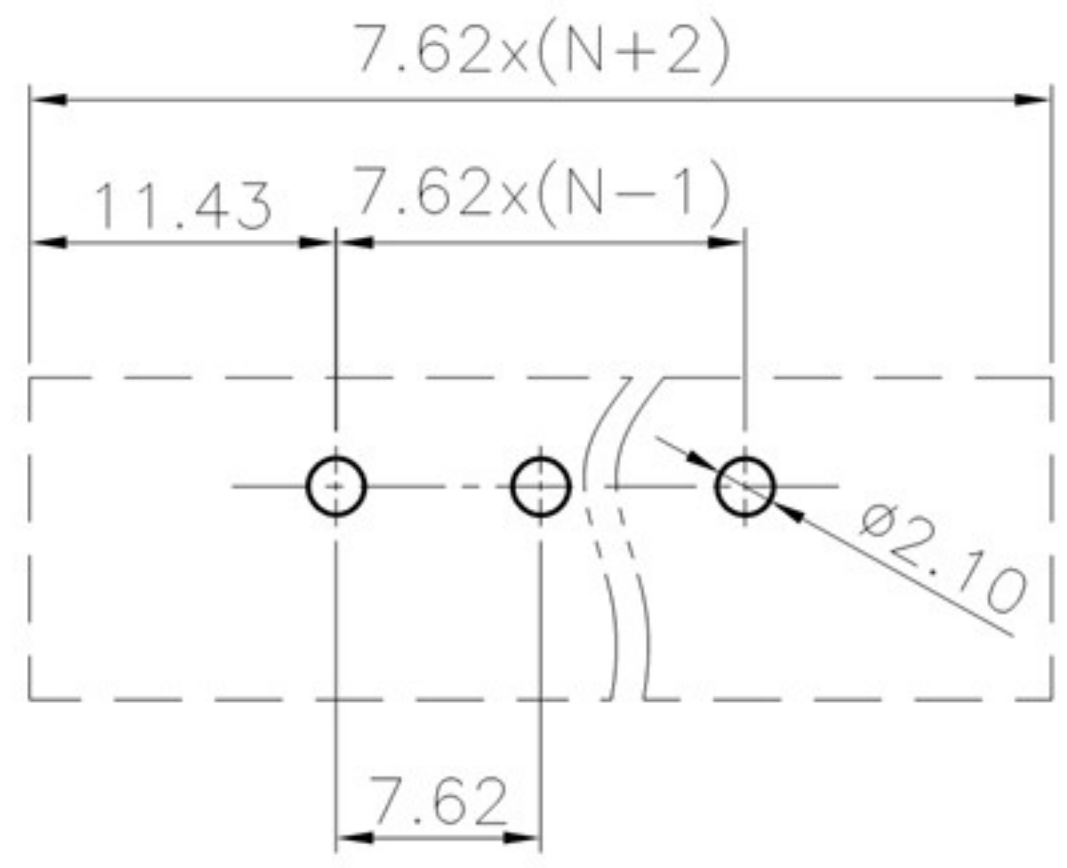

PCB LAYOUT

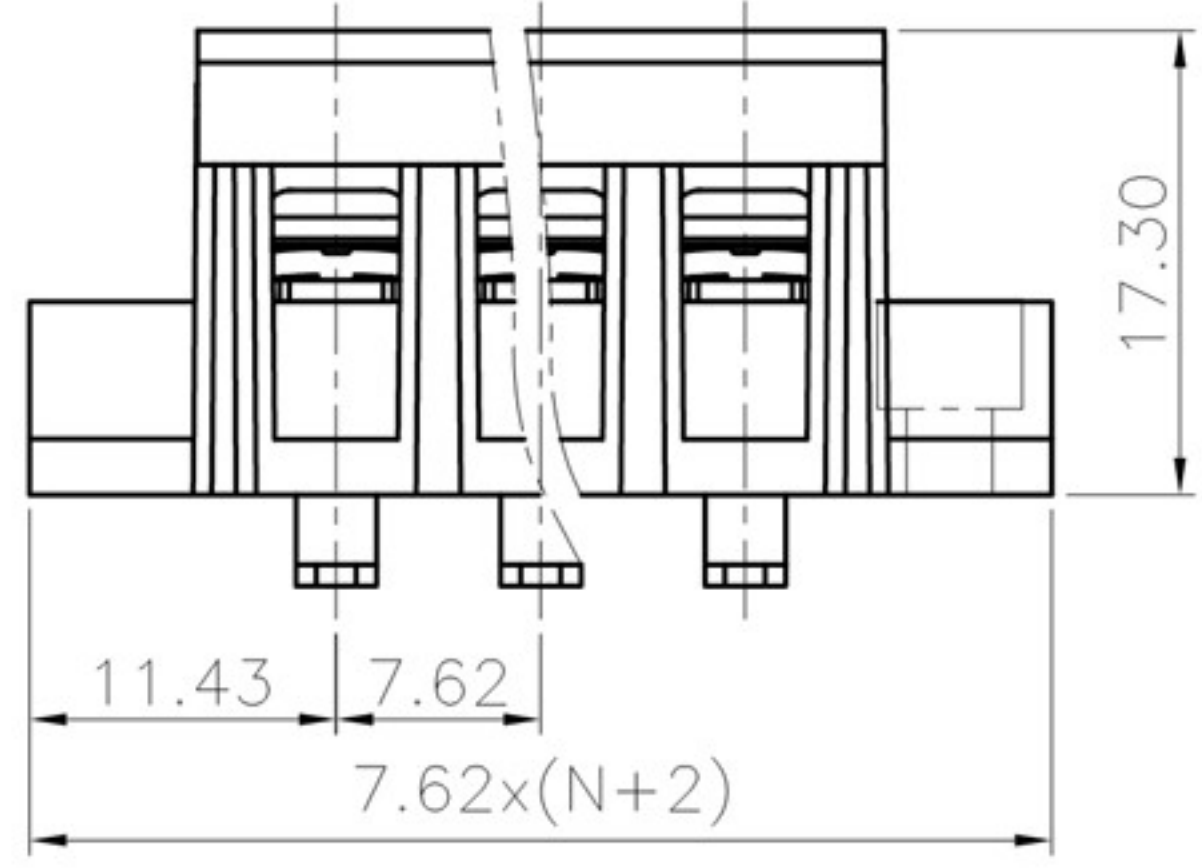
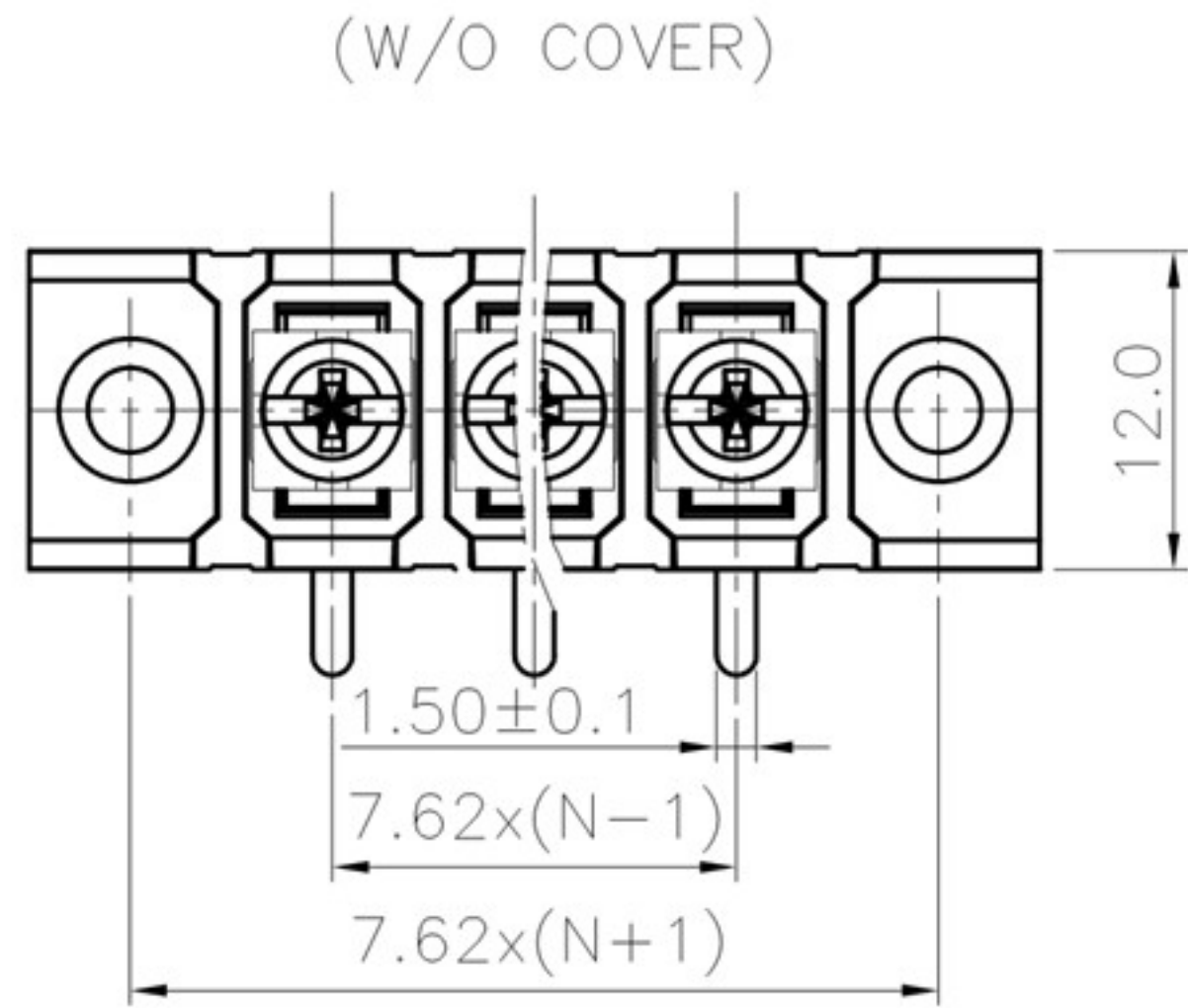
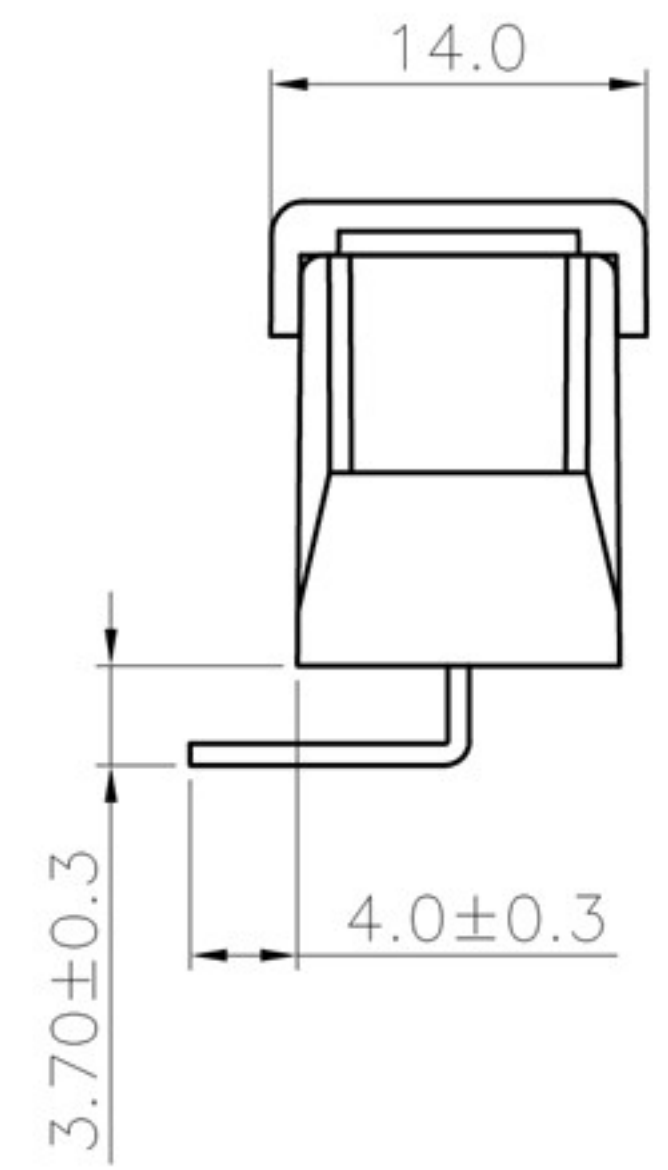

NOTES1:  
 UL Standard  
 1. Rated voltage/current : 300V / 15A  
 2. Torque value : M3 , 4.43Lb.in  
 3. Wire range : 22~14AWG

NOTES2:  
 1. Dimension shall be interpreted per ASME Y14.5-2009  
 2. Pitch : 7.62mm, Poles : N=02~24P  
 3. Withstanding voltage : AC1600V/1Min  
 4. Operating temperature: -40°C~+105°C  
 5. Undimensioned tolerances:

Pitch range in mm		Nominal dimension range in mm						-	∩	□
TO	Over TO	Over TO	Over TO	Over TO	Over TO	Over TO	0.1/10			
6	10	10	24	30	60	100	150			
±0.15	±0.20	±0.30	±0.30	±0.50	±0.70	±1.00	±1.30	±2'		

6. RoHS Compliance

DETACHED LISTS	PART NO.:	慈溪市美感电子接插件厂 Cixi Meigan Electric Appliance Socket Factory			
	APPD:	NAME: MG28RM-7.62			
	CHKD:	TITLE: CUSTOMER DRAWING			
	DRFT:	REV	DO		
	THIRD ANGLE PROJECTION	DRAWING NO.:	SHEET	1/1	
	MM (INCH)	DO NOT SCALE DRAWING	SCALE	1:1	